

July 29, 2022

From the office of:

Idaho Department of Parks and Recreation – Development Bureau
5657 Warm Springs Avenue
Boise, Idaho 83716

**Re: IDPR Project No. 310112
Priest Lake State Park – White Pine Campground Electrical Upgrades
Idaho Department of Parks & Recreation
Coolin, Idaho**

NOTICE OF CHANGES:

This **Addendum No. One** is hereby made a part of the project requirements and contract documents for the referenced project. Be sure to acknowledge this addendum on your Bid/Proposal Form. Failure to do so may subject the bidder to disqualification.

It is the obligation of the General Contractors receiving sub-bids to notify their subcontractors and suppliers of items relating to their bid prior to the bid opening.

GENERAL:

1. Bid due date is extended to **Monday, August 8, 2022 at 2pm**, local time, at the IDPR Coeur d'Alene office.
2. An updated Bid Proposal form is attached with the following updates:
 - a. Base Bid remains unchanged.
 - b. Alternate 1 remains unchanged.
 - c. Alternate 2, only purchase Panelboards A and B on Drawing Sheet E2.3 and deliver to IDPR at Priest Lake. No onsite work and no allowance to the utility company.
 - d. Alternate 3 removed.
3. Substantial Completion: Due to availability of the panelboards, the Substantial Completion date is modified to:
 - a. 80 Days to complete trenching, backfill, compaction, asphalt patches, and water service connections.
 - b. May 10, 2023, to complete all electrical work including inspection and approval.
 - c. Contractor shall submit schedule with expected material availability dates to Owner and Design Professional for approval before starting work.

QUESTIONS AND ANSWERS:

What size and materials are the existing water lines?

The existing stubs into each campsite are ½" galvanized and ½" poly.

What grounding needs to occur at the panelboards?

All grounding electrode conductors need to be connected to the same neutral bus in the panelboard to form one common grounding electrode system.

The 1/0 copper grounding electrode conductor needs to be bonded to all three of the 4" vertical posts. Bonding to the vertical posts may be done with exothermic weld, listed lugs, listed pressure connector, or listed clamps.

Is the attached valve box from Dura an acceptable substitute to the Carson valve box?

If the Carson valve boxes are not readily available, the Dura box is an acceptable substitute.

ATTACHMENTS:

1. Cut sheet for Dura Valve Box
2. Revised Bid Proposal Form

END OF ADDENDUM NO. ONE



QUALITY BY DESIGN

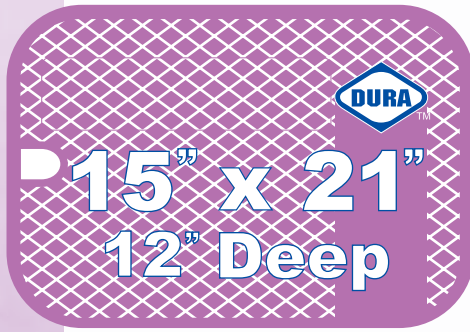

LID MARKED "WATER". WILL INCLUDE LOCK DOWN KIT.

BOX & LID COMBOS

BOX	COLOR		PART NUMBER
		LID	
BLACK	GREEN	GREEN	150
GREEN	GREEN	GREEN	151
TAN	TAN	TAN	152
PURPLE	PURPLE	PURPLE	153
BLACK	BLACK	BLACK	154
GREY	GREY	GREY	155

SEPARATES

COLOR	LID PART NO.	BODY PART NO.
GREEN	T151	B151
TAN	T152	B152
PURPLE	T153	B153
BLACK	T154	B154
GREY	T155	B155

RECTANGULAR VALVE BOX

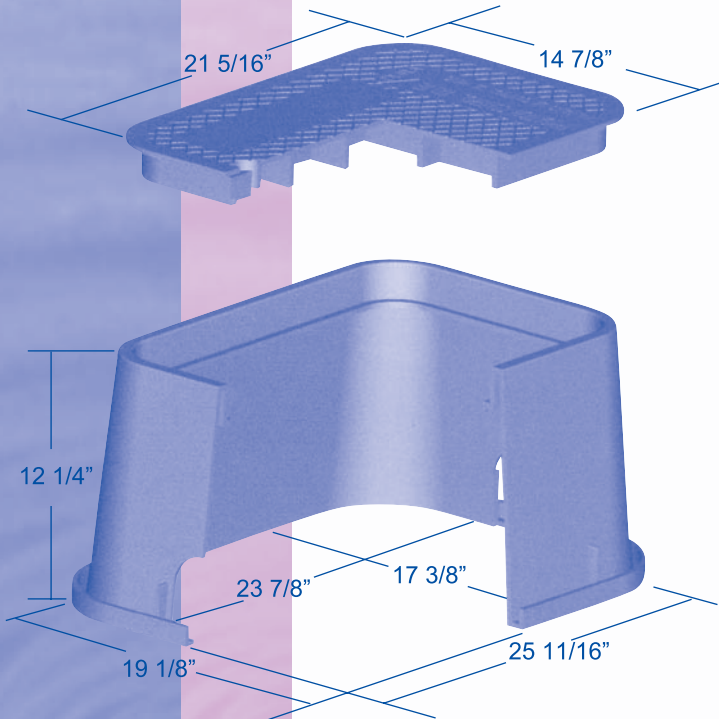

LID ENGRAVING

All lids are shipped engraved with: "IRRIGATION CONTROL VALVE" unless ordered as follows:

Designation:	Body & Lid	Lid
TELEPHONE	15_-T	T15_-T
ELECTRIC JUNCTION	15_-E	T15_-E
LOW VOLTAGE		
LANDSCAPE LIGHTING	15_-L	T15_-L

ORDER EXAMPLE: To order a Green box/lid combo engraved with "TELEPHONE" you would select "151-T" or for a black lid only you would select "T154-T"

Shipping:

Standard Pallet = 48 pcs

Ask your rep how you can save money by buying container loads direct.

20 Container	18 Pallets	40 pcs per pallet
40 Container	40 Pallets	48 pcs per pallet

FOR USE IN NON-VEHICULAR TRAFFIC AREAS. WEIGHTS AND DIMENSIONS MAY VARY.

BID PROPOSAL

TO: STATE OF IDAHO
IDAHO DEPARTMENT OF PARKS & RECREATION

Gentlemen:

The Bidder, in compliance with your Invitation for Bids for the construction of IDPR Project No: 310112, White Pine Campground Electrical Upgrades, Priest Lake State Park, Coolin, ID, having examined the bidding and Contract Documents and the site of the proposed Work, and being familiar with all of the conditions surrounding the construction of the proposed Project, including the availability of materials and labor, hereby proposes to furnish all labor, materials and supplies and to provide the service and insurance in accordance with the Contract Documents, within the time set forth therein, and at the prices stated below. These prices are to cover all expenses incurred in performing the Work required under the Contract Documents.

Bidder hereby agrees to commence Work under this Contract on a date to be specified in the written "Notice to Proceed" of the Owner and to substantially complete the Project within 80 consecutive calendar days thereafter, as stipulated in the specifications. Bidder further agrees to pay as liquidated damages, the sum of \$400.00 for each consecutive calendar day after the established substantial completion date or adjusted date as established by change order. Anticipated start of construction is September 12, 2022.

Bidder acknowledges receipt of Addenda No. _____.
(List all Addenda)

<i>Quantity</i>	<i>Amount in Words</i>	<i>Amount in Numerals</i>
BASE BID PROPOSAL:		
Item No. 1 – Electrical distribution upgrades in east loop (Sites 31 through 51, H1 and H2)		
1 LS		\$
Item No. 2 – Allowance to utility company (see Specifications 26 2210-1 for more information)		
1 LS	Twenty-five thousand dollars	\$ 25,000.00
TOTAL BASE BID AMOUNT:		
1 LS		\$

<i>Quantity</i>	<i>Amount in Words</i>	<i>Amount in Numerals</i>
ALTERNATE 1 PROPOSAL:		
Item No. 1 – Replace water service connections in east loop (Sites 31 through 51, H1 and H2)		
1 LS		\$
TOTAL ALTERNATE 1 AMOUNT:		
1 LS		\$

Quantity	Amount in Words	Amount in Numerals
ALTERNATE 2 PROPOSAL:		
Item No. 1 – Provide Panelboards A and B shown on Drawing E2.3. No onsite work.		
2 LS		\$
TOTAL ALTERNATE 2 AMOUNT:		
2 LS		\$

Bidder understands that the Owner reserves the right to reject any or all bids and to waive any informality in the bidding.

The bidder agrees that this bid shall be good for a period of forty-five (45) consecutive calendar days after the scheduled opening time for receiving bids.

Upon receipt of written Notice of Intent to Award of this bid, Bidder will execute the formal Contract within ten (10) business days and deliver a Surety Bond or Bonds as required by paragraph "Performance and Payment Bonds" first page (ITB-1) of the Instructions to Bidders.

The bid security in the amount of five percent (5%) of the bid amount is to become the property of the Owner, in the event the Contract and bond are not executed within the time set forth, as liquidated damages for the delay and additional expense to the Owner caused thereby.

The names and addresses of the entities who will perform the Work identified below, subject to approval of Owner and Architect, if Undersigned is awarded the Contract, are as follows:

Plumbing (PWCL Category 15400)

(Name) _____

(Address) _____

Idaho Public Works Contractors License No. _____

Idaho Plumbing Contractors License No. _____

Electrical (PWCL Category 16000)

(Name) _____

(Address) _____

Idaho Public Works Contractors License No. _____

Idaho Electrical Contractors License No. _____

FAILURE TO NAME A PROPERLY LICENSED SUBCONTRACTOR IN EACH OF THE ABOVE CATEGORIES MAY RENDER THE BID UNRESPONSIVE AND VOID.

Should the listing of subcontractors change due to selection of alternates or other similar circumstances, attach explanation.

Bidder warrants that bid has been prepared and that any contract resulting from acceptance of this bid is subject to the Fixed Price Construction Contract.

The undersigned notifies that it is of this date duly licensed as an Idaho Public Works Contractor and further that it possesses Idaho Public Works Contractor's License No. _____, and is domiciled in the State of _____.

Dated this _____ day of _____, _____.
(date) (month) (year)

Respectfully submitted by:

(Company)

(Seal - if bid is by a corporation)

(Street or PO Address)

(City, State and zip code)

(Authorized Signature)

(Title)

(Telephone Number)

(FAX Number)

(Email Address)

Have you remembered to include bid security (bid bond or a certified or cashier's check), Contractor's Affidavit Concerning Alcohol and Drug-Free Workplace and a signed copy of the Bidder's Acknowledgment Statement with your bid?

Execute and Submit with Bid

**CONTRACTOR'S AFFIDAVIT
CONCERNING ALCOHOL AND DRUG-FREE WORKPLACE**

STATE OF _____

COUNTY OF _____

Pursuant to the Section 72-1717, Idaho Code, I, the undersigned, being duly sworn, depose and certify that _____ is in compliance with the provisions of Section 72-1717, Idaho Code; that _____ provides a drug-free workplace program that complies with the provisions of Title 72, Chapter 17, Idaho Code, and will maintain such program throughout the life of a state construction contract; and that _____ shall subcontract Work only to subcontractors meeting the requirements of Section 72-1717(1)(a), Idaho Code.

Name of Contractor

Address

City and State

By: _____
(Signature)

Subscribed and sworn to before me this _____ day of _____, _____.

NOTARY PUBLIC

Residing at: _____

Commission expires: _____

FAILURE TO EXECUTE THIS AFFIDAVIT AND SUBMIT IT ALONG WITH YOUR BID SHALL MAKE YOUR BID NON-RESPONSIVE.

Execute and Submit with Bid

BIDDER'S ACKNOWLEDGMENT STATEMENT

NOTE: THE INFORMATION CONTAINED HEREIN IS A SUMMARY OF VITAL CONTRACT PROVISIONS AND DOES NOT CHANGE THE CONTRACT DOCUMENTS THAT WILL GOVERN THIS PROJECT.

Idaho Department of Parks & Recreation Project No. 310112, White Pine Campground Electrical Upgrades, Priest Lake State Park, Coolin, ID

By submitting a bid for this Project, the undersigned bidder agrees that, if awarded the Contract for construction, Contractor will conform to all conditions and requirements of the Contract, including but not limited to:

- Contractor agrees to comply with conditions pertaining to Sections 44-1001 and 44-1002, Idaho Code, requiring the employment of ninety-five percent (95%) bona fide Idaho residents and providing for a preference in the employment of bona fide Idaho residents and regarding the employment of persons not authorized to work in the United States.
- Contractor will substantially complete the Work within the time stated in the Contract Documents, or as modified by Change Order(s).
- If the Contractor fails to substantially complete the Project within the time stated in the Contract Documents, or as modified by Change Order, the Contractor agrees that the Owner may deduct from the Contract amount liquidated damages in the amount per calendar day, indicated in the Contract Documents, times the number of calendar days until the Project is Substantially Complete, as defined in the Contract Documents and as determined by the Design Professional.
- The Contractor agrees that the amount allowed for overhead and profit on any Change Order is limited to the amounts indicated in subparagraph 16.3.11 of the Fixed Price Construction Contract Between Owner and Contractor.
 1. For total changes the amount allowed for overhead, profit, bonds and insurance for the Contractor and all subcontractors of any tier combined shall not exceed fifteen percent (15%) of direct costs; or
 2. The Contractor will determine the amount of overhead and profit to be apportioned between the Contractor and its subcontractor of allowable amounts of overhead, profit, bonds and insurance.
- The Contractor agrees that Change Orders are governed by the Fixed Price Construction Contract Between Owner and Contractor General Conditions of the Contract for Construction including as follows:
 1. By the execution of a Change Order, the Contractor agrees and acknowledges that it has had sufficient time and opportunity to examine the change in Work which is the subject of the Change Order and that it has undertaken all reasonable efforts to discover and disclose any concealed or unknown conditions which may, to any extent, affect the Contractor's ability to perform in accordance with the Change Order. Aside from those matters specifically set forth in the Change Order, the Owner shall not be obligated to make any adjustments to either the Contract Sum or Contract Time by reason of any conditions affecting the change in Work addressed by the Change Order that could have reasonably been discovered or disclosed by the Contractor's examination.

2. Any Change Order fully executed by the Owner, Contractor and Design Professional, including but not limited to, a Change Order arising by reason of the parties' mutual agreement or by mediation, shall constitute a final and full settlement of all matters relating to or affected by the change in the Work, including but not limited to, all direct and consequential costs associated with such change and any and all adjustments to the Contract Price and Contract Time. In the event a Change Order increases the Contract Price, the Contractor shall include the Work covered by such Change Order in the Application for Payment as if such Work was originally part of the Project and Contract Documents.

FAILURE TO EXECUTE THIS ACKNOWLEDGMENT MAY MAKE YOUR BID NON-RESPONSIVE.

I, _____, being duly authorized to bind the
(type or print name of individual)

bidder, _____, does hereby certify that I have fully read
(type or print name of company)

and understand this document and that it highlights certain parts of the Contract that will be entered between the parties and that will govern this Project.

Authorized Signature: _____

Title: _____

Date: _____

END OF BIDDER'S ACKNOWLEDGMENT STATEMENT